

SURFACE MOUNT CHIP LED LAMPS

DATA SHEET

MODEL NO: GT3528-4W60CXX

REV. : 2.0

DATE : 05-MAr.-2011

Features

- P-LCC-2 package.
- White package.
- Optical indicator.
- Colorless clear window.
- Pb-free.
- Wide viewing angle.
- Compatible with automatic placement equipment.
- Available on tape and reel .
- Suitable for vapor-phase reflow, Infrared reflow and wave solder processes.
- The product itself will remain within RoHS compliant version



Descriptions

The GT3528 series is available in soft orange, green, blue and yellow. Due to the package design, the LED has wide viewing angle and optimized light coupling by inter reflector. This feature makes ideal for light pipe application. The low current requirement makes this device ideal for portable equipment or any other application where power is at a premium.

Applications

- Telecommunication: indicator and backlighting in telephone and fax.
- Flat backlight for LCD, switch and symbol.
- Light pipe application.
- General use.

Device Selection Guide

Material	Resin (mold)	Emitted Color
InGaN	Epoxy	White

Package Dimensions

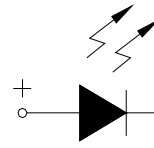
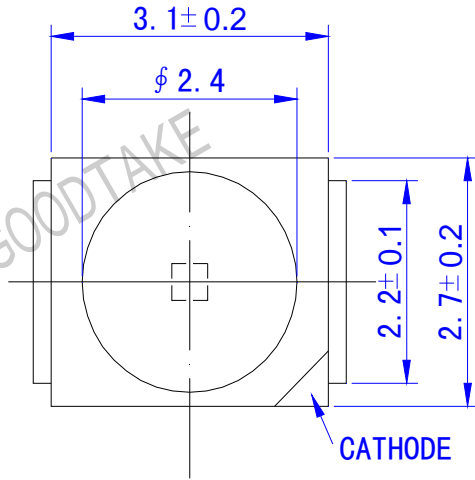

Polarity

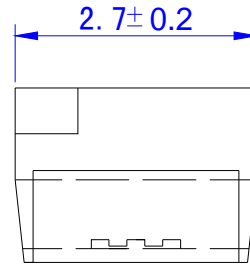
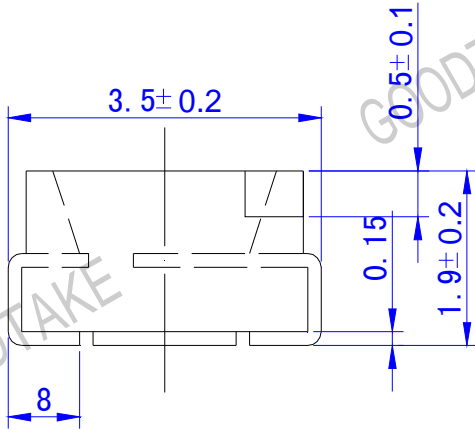

For reflow soldering (Proposal)

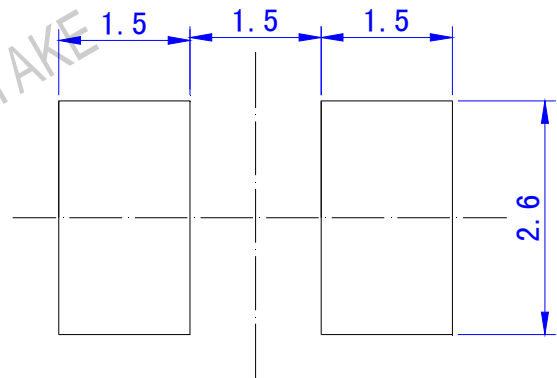
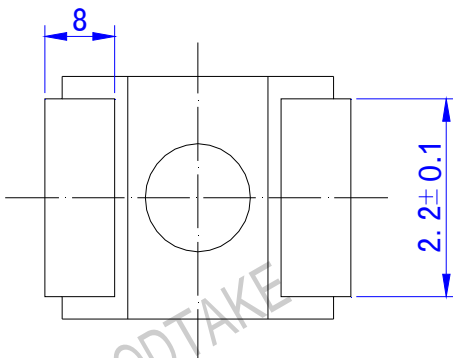

Note: The tolerances unless mentioned is $\pm 0.1\text{mm}$, Unit = mm

Absolute Maximum Rating (Ta=25°C)

Item	Symbol	Condition	Absolute Maximum Rating	Unit
Forward Current	I _F		30	mA
Peak Forward Current	I _{FP}	Duty1/10 @1Khz)	100	mA
Reverse Voltage	V _R		5	V
Power Dissipation	P _D		102	mW
Operating Temperature	T _{opr}		-40~+85	°C
Storage Temperature	T _{stg}		-55~+100	°C
Electrostatic Discharge	ESD		2000 (HBM)	V
Lead Soldering Temperature	T _{sol}		260°C for 10 seconds	

Electrical and Optical Characteristics at (Ta=25°C)

Item	Symbol	Condition	Min	Typ	Max	Unit
Forward Voltage	V _F	I _F =20mA	2.9	---	3.3	V
50%Power angle	2θ _{1/2}		--	120	--	Deg
Luminous Intensity	I _v		2400	----	3200	Mcd
Chromaticity Coordinates	CIE-X		0.3782	--	0.4946	--
	CIE-Y		0.3620	--	0.4551	--
Reverse Current	I _R	V _r =5V			5	μA

Luminous Intensity Combination(mcd at 20mA)

Rank	Min (mcd)	Max (mcd)
H	2400	2600
I	2600	2800
J	2800	3000
K	3000	3200

***Measurement Uncertainty of Luminous Intensity: $\pm 10\%$.**

Forward Voltage Combination(V at 20mA)

Rank T	0	1	2	3
Forward Voltage	2.9~3.0	3.0~3.1	3.1~3.2	3.2~3.3

***Measurement Uncertainty of Forward Voltage: $\pm 0.1V$.**

Color Combination(at 20mA)

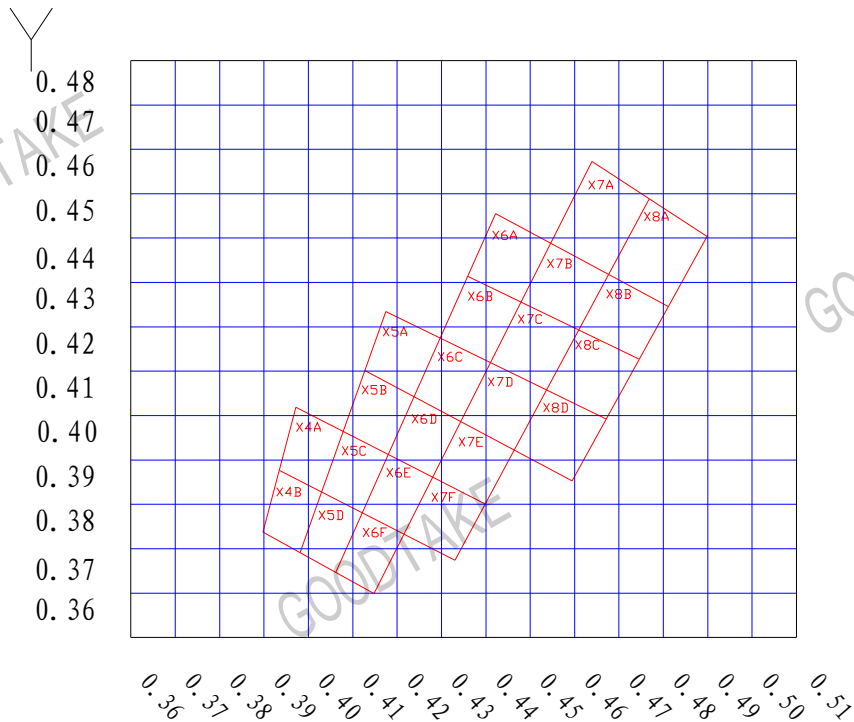

Color Ranks(IF=20mA,Ta=25°C)

Color Ranks	CIE						色温段
X8	X8A		X8B	X8C		X8D	2500-2700K
X7	X7A	X7B	X7C	X7D	X7E	X7F	2700-3000K
X6	X6A	X6B	X6C	X6D	X6E	X6F	3000-3250K
X5	X5A		X5B	X5C		X5D	3250-3500K
X4	X4A			X4B			3500-3700K

Measurement uncertainty of the color coordinates ± 0.01

Typical Electrical / Optical Characteristics Curves (25°C Ambient Temperature Unless Otherwise Noted)

Luminous Intensity vs Ambient Temperature

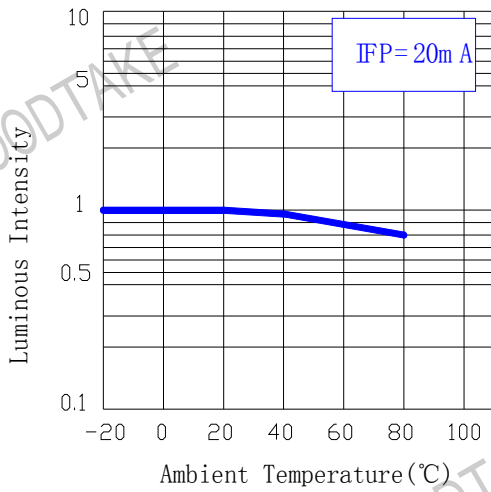

Relative Intensity vs Forward Current (mA)

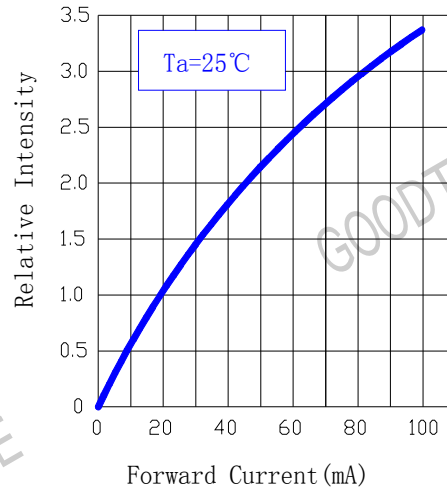

Forward Current vs Ambient Temperature

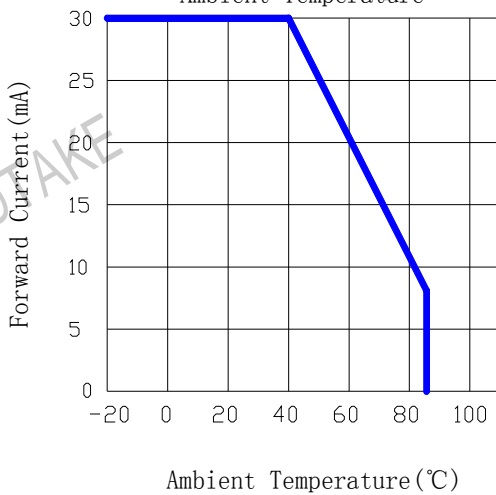

Forward Current vs Forward Voltage

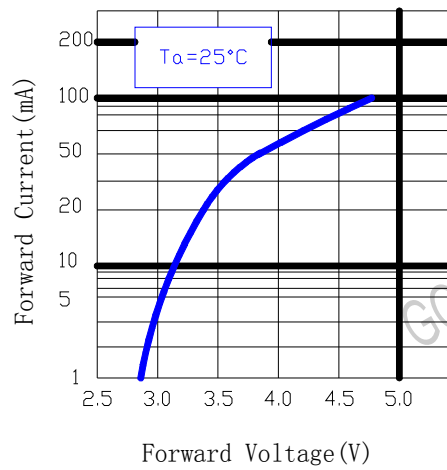

Duty Ratio vs. Allowable Forward current

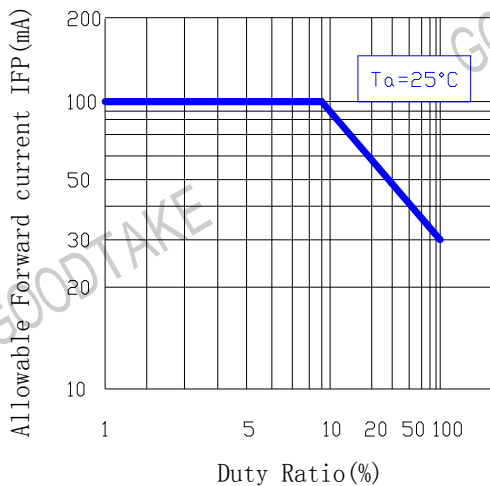

Forward Voltage vs. Ambient Temperature

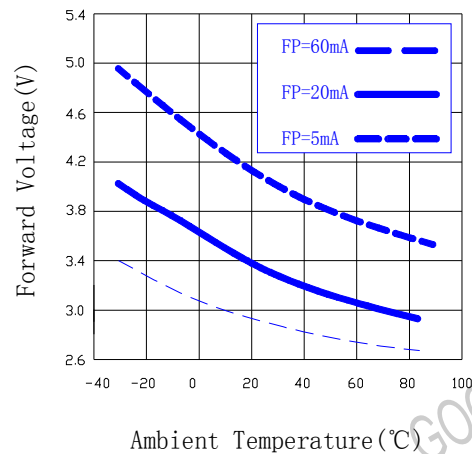

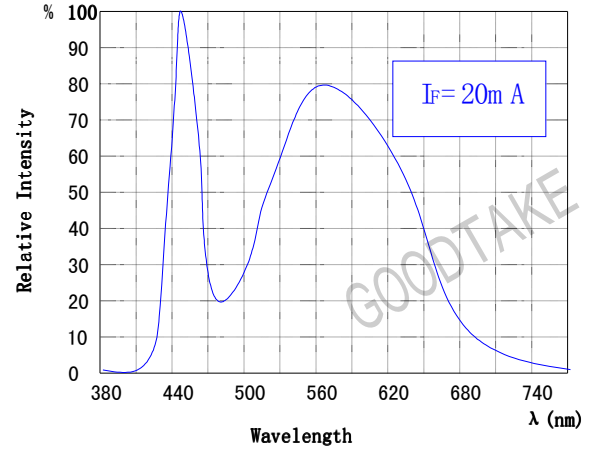
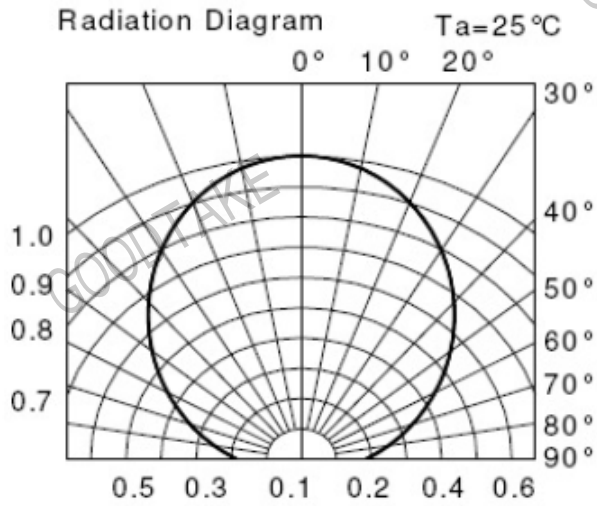

Test items and results of reliability

NO	Item	Test Conditions	Test Hours/Cycle	Sample Size	Ac/Re
1	Reflow	TEMP: $260\pm 5^\circ\text{C}$ Min. 5sec.	6 MIN.	22 PCS	0/1
2	Temperature Cycle	H: $+100^\circ\text{C}$ 15min 5 min L: -40°C 15min	300 CYCLES	22 PCS	0/1
3	Thermal Shock	H: $+100^\circ\text{C}$ 5min 10 sec L: -10°C 5min	300 CYCLES	22 PCS	0/1
4	High Temperature Storage	TEMP: 100°C	1000 HRS	22 PCS	0/1
5	Low Temperature Storage	TEMP: -55°C	1000 HRS	22 PCS	0/1
6	DC Operating Life	$I_f = 20\text{ mA} / 25^\circ\text{C}$	1000 HRS	22 PCS	0/1
7	High Temperature / High Humidity	$85^\circ\text{C} / 85\%RH$	1000 HRS	22 PCS	0/1

Taping Specification

(1) Shape and dimensions of reels: unit in mm

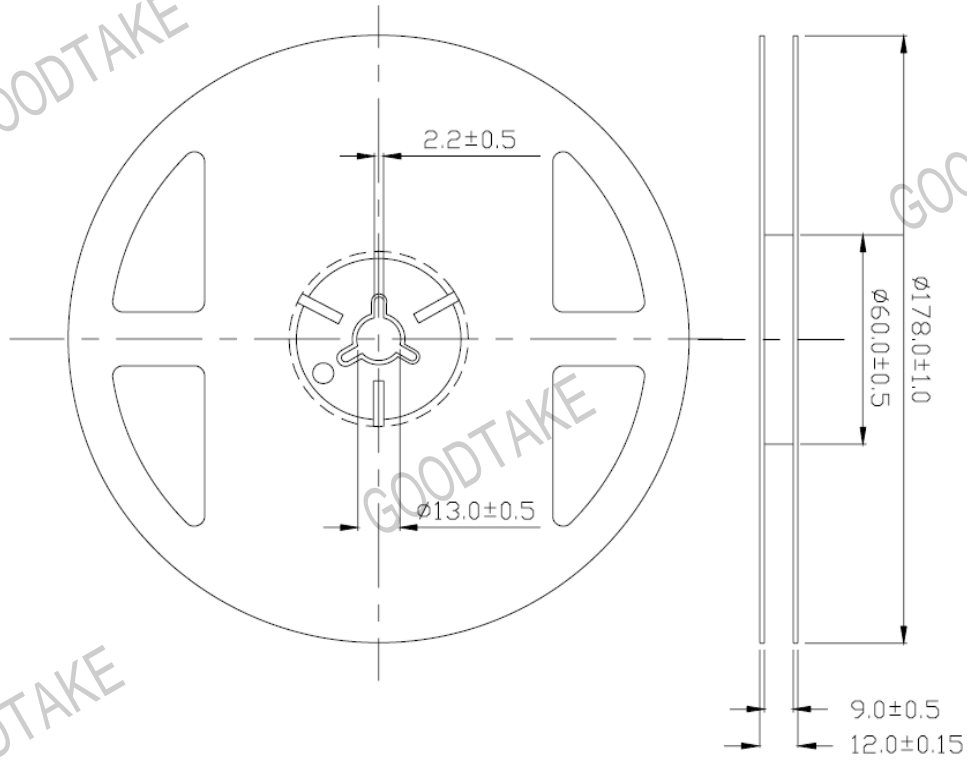

(2) Dimensions of tape

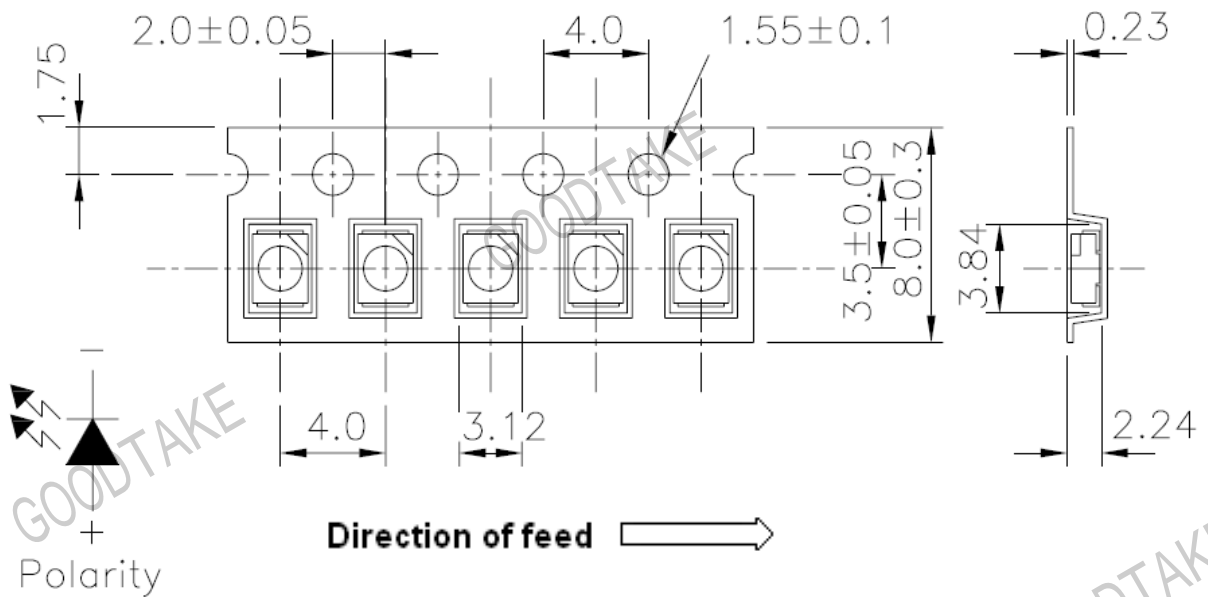

Packing Information

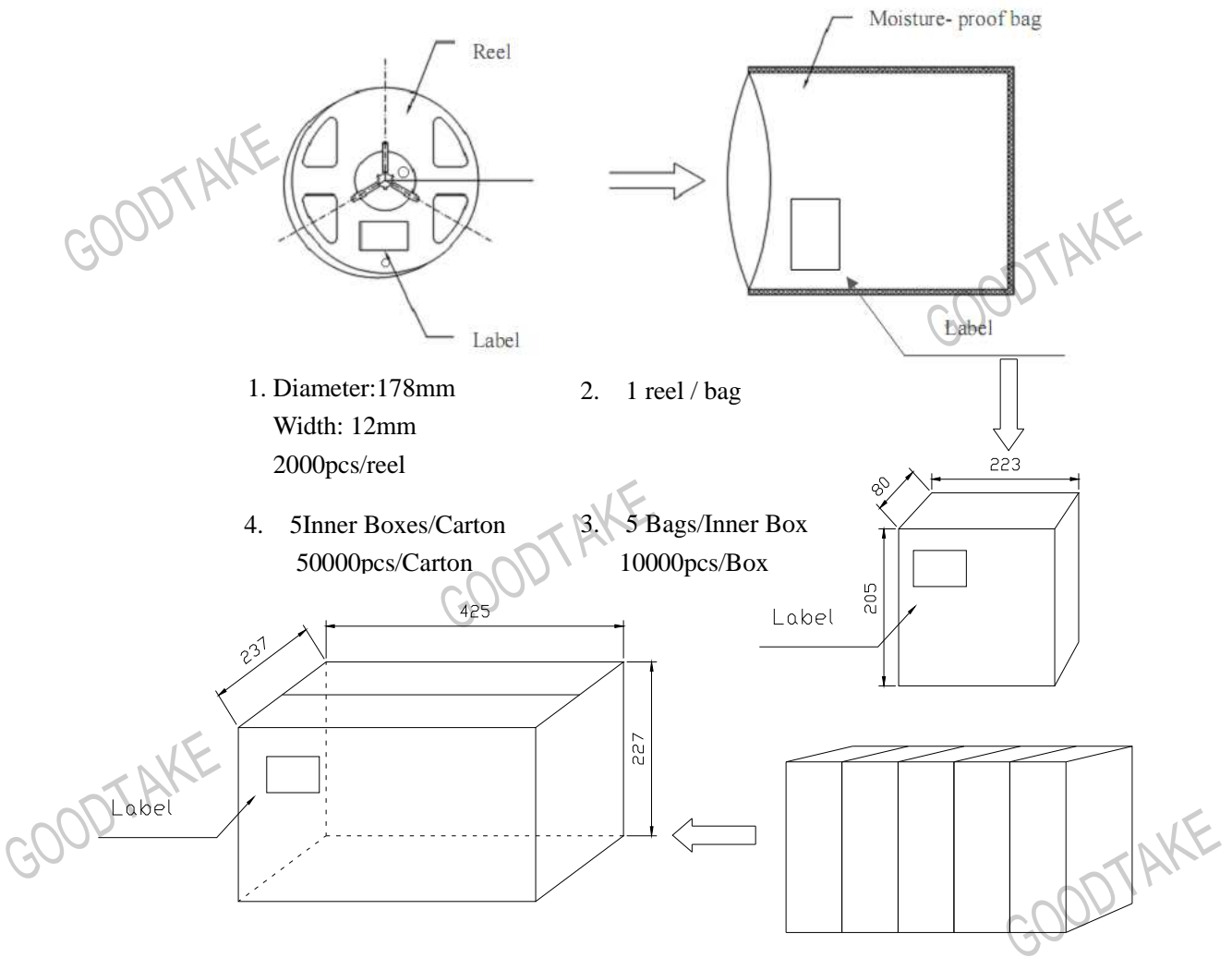

Soldering Condition

1. Pb-free solder temperature profile

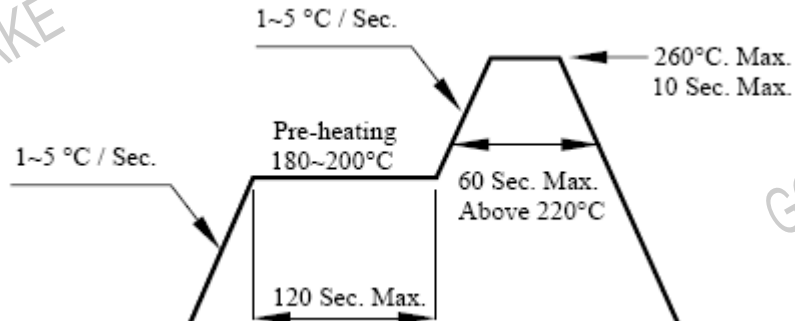

2. Reflow soldering should not be done more than two times.
3. When soldering, do not put stress on the LEDs during heating.
4. After soldering, do not warp the circuit board.

Soldering Iron

Each terminal is to go to the tip of soldering iron temperature less than 350°C for 3 seconds within once in less than the soldering iron capacity 25W. Leave two seconds and more intervals, and do soldering of each terminal. Be careful because the damage of the product is often started at the time of the hand solder.